



The gold standard for track and trace integration

Thermal Inkjet

Wolke m600[®] oem



Wolke engineering — built to fit, designed to perform

The gold standard for global track and trace applications

Wolke — the trusted leader in thermal inkjet innovation

Since Wolke launched the first high resolution, low maintenance printing system in 2000, the brand has become the trusted leader in Thermal Inkjet (TIJ) coding technology for high value applications. Now with over 10,000 successful installs worldwide, the Wolke engineers have created a new state of the art – the m600 oem. Intelligent in design and practical in build, the m600 oem delivers breakthrough integration versatility combined with the industry's most powerful data handling and global track and trace capabilities.

The m600 oem offers complete backwards compatibility with the known and trusted m600 advanced, allowing use of the same remote communication protocols, printheads, layout files, and accessories. And yet, the m600 oem represents an entirely new class of track and trace coding system.

Ultimate flexibility when integration matters

The m600 oem controller is up to 60% smaller than comparable TIJ printers, offering system integrators and serialization OEMs a uniquely small and lightweight solution. The possibility of 18 different mounting orientations and four unique printhead designs helps address the common challenges of integrating into sophisticated packaging and serialization machinery. The option to connect up to six printheads, running any four simultaneously, creates new possibilities for switching seamlessly between different print locations on the package without mechanical adjustment.

A 3.5" one-way controller display allows simple scroll to diagnostic information with no possibility of data entry or configuration. All printer operation and settings are managed exclusively via the host packaging line HMI, enabling unrivaled security. In addition, a remote web browser interface provides simple and flexible set up with four levels of user password protections and comprehensive logging, guarding printer access and supporting CFR21 part11 compliance.

Meet present and future serialization requirements

Serialization is Wolke's legacy. And the m600 oem printer makes clear why.

The Wolke m600 oem establishes the standard for a new generation of track and trace projects, featuring:

- Powerful new processing hardware and a formidable data buffer for serialized record management
- Validated Wolke remote commands and data handling protocols
- Unicode TrueType® fonts for global projects
- Innovative asynchronous communications practices

Active User Datagram Protocol (UDP) alerts provide new options for proactive notification to a host system for defined events, such as when a configurable safety buffer threshold has been reached. In addition, one-to-one confirmation of printed records informs the host system exactly which codes have been processed, eliminating the risk of lost or wasted codes, even through power outages.



Proven technology backed by a 5-year warranty*



**Warranty subject to local Wolke/Videojet country warranty policy*

Powerful Data Handling

Secure, ultra-fast processing of 20 unique records per second, and printing of 2D DataMatrix or GS1 128 bar codes.

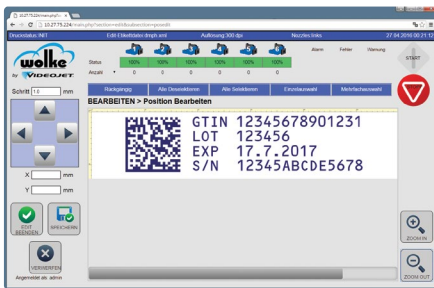

Flexible web interface enables easy print control from any large screen user interface.

GTIN 12345678901231
LOT 123456
EXP 17.07.2017
S/N 12345ABCDE5678

Innovative Productivity

Perpetuo Print Mode™ extends production runs. Replenish ink without stopping the line.

Integration

Compact, versatile controller mounting for easiest cabinet integration. 24V DC power for low heat emissions.



Advanced innovation drives productivity

	GTIN 12345678901231 LOT 123456 EXP 17.07.2017 S/N 12345ABCDE5678		GTIN 12345678901231 LOT 123456 EXP 17.07.2017 S/N 12345ABCDE5678		GTIN 12345678901231 LOT 123456 EXP 17.07.2017 S/N 12345ABCDE5678
300 dpi / 300 dpi	438 nl* ink per print	300 dpi / 240 dpi	407 nl ink per print	300 dpi / 180 dpi	386 nl ink per print

*Printed with WOLKE60068
Premium Black

* nl = nanoliter = one billionth of a liter

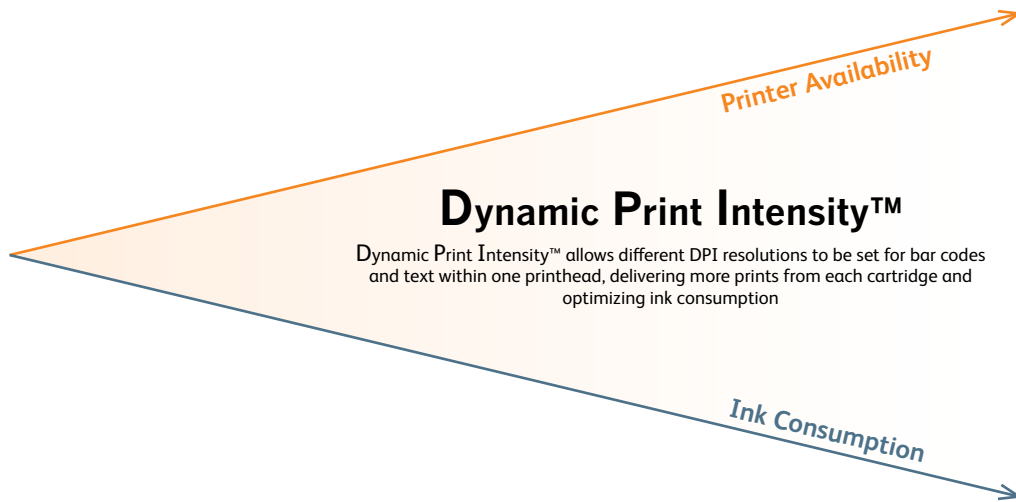

New ink capabilities

The specialized portfolio of Wolke TIJ inks has been optimized for critical applications. The inks deliver outstanding print contrast and light-fastness, in combination with long de-cap times.



Four printhead designs for integration into tight spaces

Wolke Premium Black

Premium Black is a fast-drying and highly reliable ink offering unrivaled high contrast prints. The ink was specifically developed by Videojet for optimum performance in Wolke TIJ systems where optical density and ultra dark codes are required for reliable scanning of bar codes or text. High contrast codes printed with Premium Black ink exhibit excellent light-fastness to stage WS 6*.

Wolke Universal Black

Universal Black is a proven standard ink for Wolke TIJ, with installs throughout the pharmaceutical, tobacco and food industries. It's combination of long de-cap times and short drying times is useful for printing on uncoated and painted cardboard and other paper substrates.

Wolke Water-Resistant Black

Water-Resistant Black is a very good solution for moist and /or cold product applications.

The specialized formulation minimizes bleeding or smearing of ink when the packaging is exposed to moisture or condensation after printing. This solution is particularly useful for pharmaceutical cold chain applications.

Wolke Black Solvent

Black Solvent unlocks extraordinary new applications for TIJ marking on many non-porous materials such as glossy cartons, blister foils, coated labels or soft plastics.

While not equivalent to MEK in adhesion, Black Solvent offers all-new applications for Wolke TIJ on pharmaceutical materials beyond paperboard cartons.

*WS 6 = very good according to blue wool scale Standard paper APCO II / II in accordance with DIN ISO 12040th.

Wolke m600® oem

Thermal Inkjet

Hardware

Line speed/resolution capability

Maximum 300mpm (984fpm)
Maximum resolution of 600x600 dpi
Line speed dependent on selected print resolution

Display

3.5" resistive display; auto-rotates in any orientation

Memory

512 MB
Configurable variable data buffer

Data connectivity

Differential Encoder, 24V DC I/O connector, Ethernet, TCP/IP, FTP, USB-A

Controller dimensions

8.7" (220mm) long x 7.8" (200mm) wide x 3.15" (80mm) high

Printhead

Connect up to 6 printheads, with any 4 printing simultaneously, for maximum flexibility
Choice of 4 printhead designs for optimal integration in tight spaces
Fully compatible with m600 advanced printheads

Environmental protection

IP20 (controller)

Temperature/humidity range

41°F to 113°F (5°C to 45°C)
Non-condensing humidity

Electrical requirements

External 24 V DC power supply, 150 Watt

Approximate weight (controller)

4.85lbs (2.2kg)

Software

Webserver

Simple user interface
Message editing capability
Single sign-on
Integrated event logging

Linear bar codes

EAN8, EAN13, UPC-A/E, CODE128, EAN128, GS1 Databar stacked/limited, 2/5i, Codabar, CODE39

2D Codes

Full suite of options, including DataMatrix, QR, GS1, PPN, HIBC, and others

Language options

English, Arabic, Bulgarian, Czech, Danish, Dutch, Finnish, French, German, Greek, Hebrew, Hungarian, Italian, Japanese, Korean, Norwegian, Polish, Portuguese, Russian, Simple Chinese, Spanish, Swedish, Thai, Traditional Chinese, Turkish, Vietnamese

Wolke Label Creator™

Supports True Type® Fonts
Enables editing or upgrade of existing m600 advanced label

Unicode (UTF8)

Print fully variable codes with non-Latin characters. Examples: 구름; облако; €

Compact Design

The Wolke m600 oem requires up to 60% less space in the electrical cabinet than comparable thermal inkjet solutions.

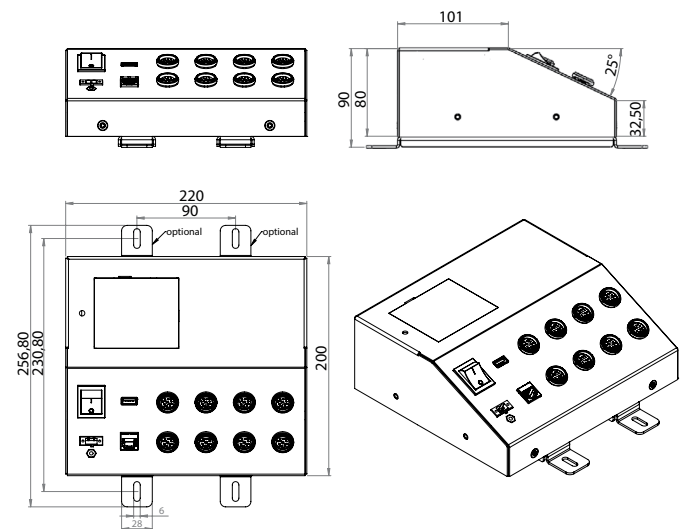
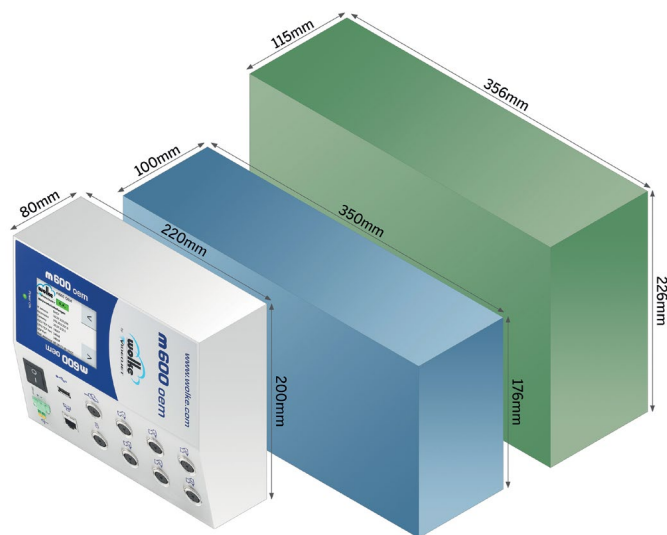

Mounting Versatility

A total of 18 mounting options in various orientations, including choice of flush-mount brackets or DIN rail mounting optimized for track and trace cabinets.



Peace of mind comes as standard

Wolke and Videojet together are a world-leader in the product identification market, providing in-line printing, coding, and marking products, application specific fluids, and product life cycle services.

Our goal is to partner with our customers in the consumer packaged goods, pharmaceutical, and industrial goods industries to improve their productivity, to protect and grow their brands, and to stay ahead of industry trends and regulations. With our customer application experts and technology leadership in Continuous Inkjet (CIJ), Thermal Inkjet (TIJ), Laser Marking, Thermal Transfer Overprinting (TTO), case coding and labeling, and wide array printing, Videojet has more than 325,000 printers installed worldwide.

Our customers rely on Wolke and Videojet products to print on over ten billion products daily. Customer sales, application, service and training support is provided by direct operations with over 3,000 team members in 26 countries worldwide. In addition, our distribution network includes more than 400 distributors and OEMs, serving 135 countries.

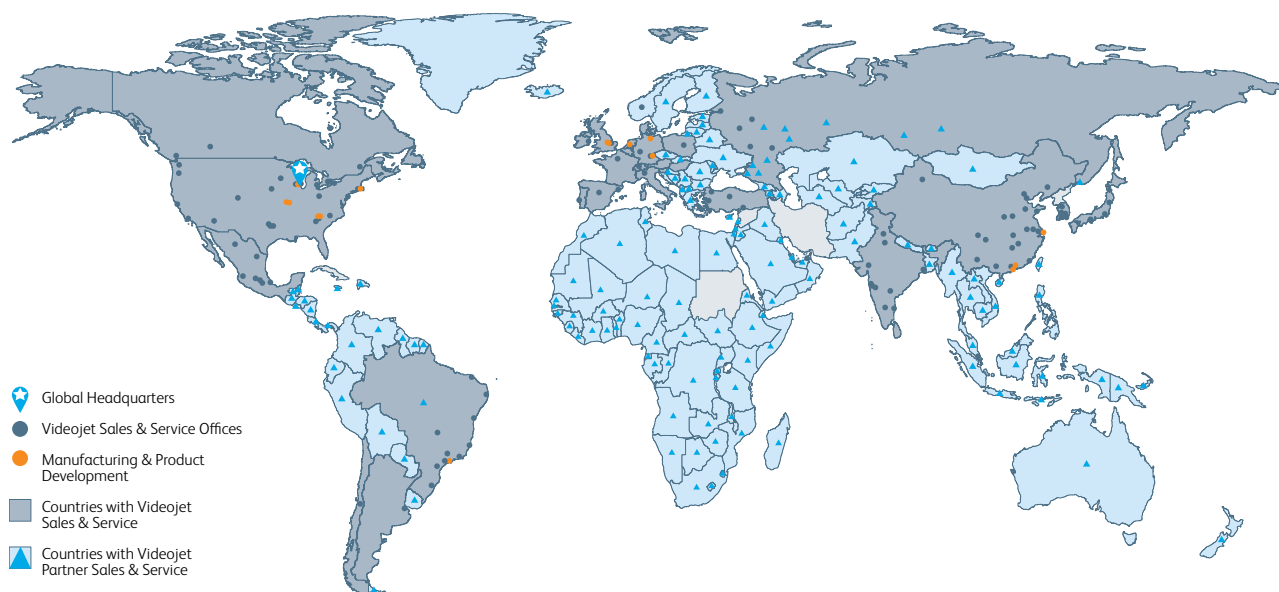

Call **+47 9041 8340**
Email **post.no@videojet.com**
or visit **www.videojet.no**
or **www.wolke.com**

Videojet Technologies Norway
Kirkegårdsveien 45
3616 Kongsberg

© 2016 Videojet Technologies Inc. — All rights reserved.

Videojet Technologies Inc.'s policy is one of continued product improvement. We reserve the right to alter design and/or specifications without notice. True Type is a registered trademark of Apple Computer, Inc.

Part No. SL000622
br-m600-oem-en-no-0616

